

# DIRTCARLIFT X-SERIES LIFT ASSEMBLY

# **WARRANTY DISCLAIMER**

## **READ BEFORE USING PRODUCT**

This product is a specialized lift designed exclusively for lightweight competition vehicles, specifically those weighing less than 4500 pounds and used off-highway. It is important to note that DirtCarLift.com does not have direct knowledge of the individuals who will utilize this lift or the specific contexts in which it will be employed.

This lift is a component that should be integrated into a larger system. It is crucial to use additional safety equipment, such as jack stands, which are not supplied with this product. Furthermore, only individuals who are proficient in operating hydraulic lifts should handle this equipment.

Due to the variable nature of how this lift may be used, DirtCarLift.com cannot provide any warranty, whether explicit or implied. The responsibility to determine the appropriateness of this lift for a particular racing application rests solely with the end user. It is imperative to understand that this lift is not designed for, nor should it be used in, vehicles that are driven on public highways. It has not been certified for such use. Improper use of this product could lead to severe injury or even fatality. The end user assumes all responsibility for any risks associated with the use of this lift.



## **BEWARE OF:**

- PINCH POINTS
- OVER TIGHTENING FASTENERS
- STRIPPING FASTNERS
- INSUFFICIENT GREASING
- LOOSE PARTS
- LOSING PARTS



## **DO NOT:**

- EXCEED WEIGHT LIMIT OF 4000 POUNDS
- CUT INTO OR SHAVE OFF ANY MATERIAL FROM THE PRODUCT
- REPLACE OR CHANGE PARTS, UNLESS OTHERWISE INSTRUCTED BY MANUFACTURER
- OPERATE A DAMAGED PRODUCT
- INSTALL OR USE PRODUCT UPSIDE DOWN
- EXCESSIVELY DRIVE BOLTS AFTER THEY HAVE BEEN FULLY SEATED
- ASSEMBLE ANY PARTS WITHOUT READING THE NOTES
- ASSEMBLE TIGHT FIT PARTS WITHOUT PROPERLY GREASING THEM
- USE INCOMPATIBLE GREASE OR HYDRAULIC FLUID WITH THE LIFT

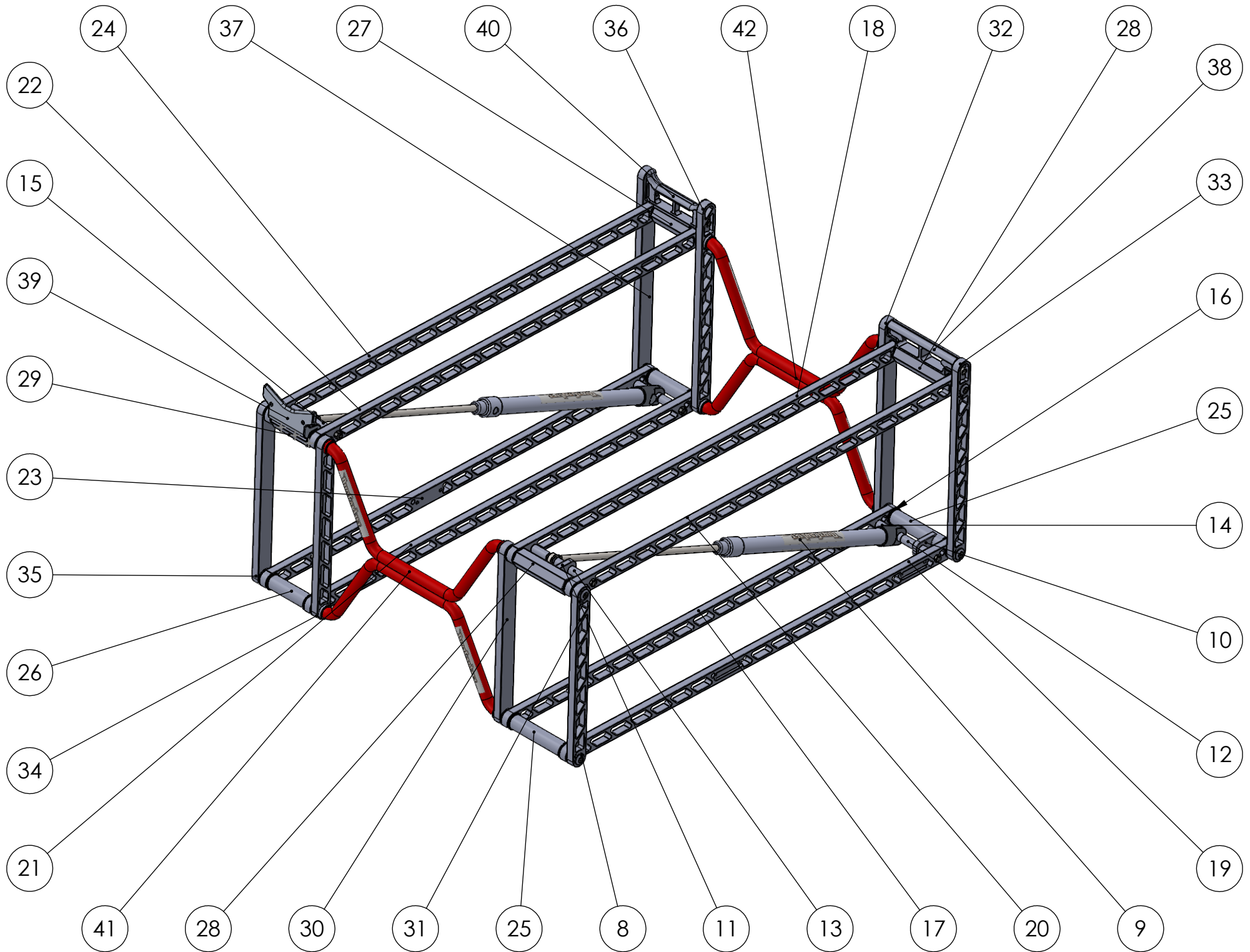

ITEM NO.	PART NUMBER	QTY.
1	3/8"X8" HEX HEAD SCREW	2
2	5/16 - 18 NUT	3
3	5/16-18X1.25 SOCKET HEAD CAP SCREW	4
4	5/16-18X2 SOCKET HEAD CAP SCREW	3
5	3/8-16 LOCKNUT	4
6	3/8X6.5 HEX HEAD SCREW	2
7	1/4-20 X 5/8 FLAT HEAD CAP SCREW	8
8	END CAP	8
9	HYDRAULIC_CYLINDERS	2
10	CYLINDER BOLT SUPPORT BOTTOM (ROUND)	1
11	CYLINDER BOLT SUPPORT TOP (HEX)	1
12	LONG CYLINDER SPACER (W/GROOVE)3.79"	1
13	LONG CYLINDER SPACER 3.625"	1
14	SHORT CYLINDER SPACER (W/GROOVE) 2.15"	3
15	SHORT CYLINDER SPACER 2.00"	3
16	BLACK SPACER	32
17	LONG LADDER (LFIB)	1
18	LONG LADDER (LFIT)	1
19	LONG LADDER (LFOB)	1
20	LONG LADDER (LFOT)	1
21	LONG LADDER (RFIB)	1
22	LONG LADDER (RFIT)	1
23	LONG LADDER (RFOB)	1
24	LONG LADDER (RFOT)	1
25	LONG TUBE SPACER (5.625")	2
26	SHORT TUBE SPACER (4.25")	2
27	LONG HEX (5.625")	2
28	SHORT HEX (4.25")	1
29	SHORT HEX W/HOLES (4.25")	1
30	SHORT LADDER (LFIT)	1
31	SHORT LADDER (LFOT)	1
32	SHORT LADDER (LRIT)	1
33	SHORT LADDER (LROT)	1
34	SHORT LADDER (RFIT)	1
35	SHORT LADDER (RFOT)	1
36	SHORT LADDER (RRIT)	1
37	SHORT LADDER (RROT)	1
38	LR RISER	1
39	RF RISER	1
40	RR RISER	1
41	XBAR FRONT	1
42	XBAR REAR	1

42: XBAR FRONT

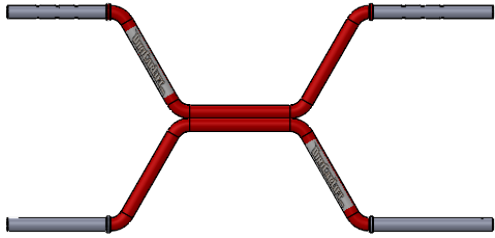

41: XBAR REAR

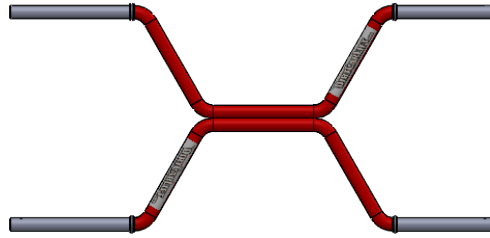

27: LONG HEX (5.625")

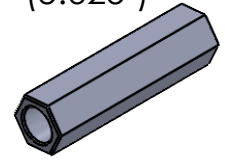

17: LONG LADDER LFIB



30: SHORT LADDER LFIT



28: SHORT HEX (4.25")

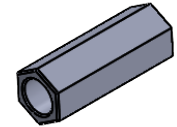

18: LONG LADDER LFIT



31: SHORT LADDER LFOT



29: SHORT HEX W/HOLES (4.25")

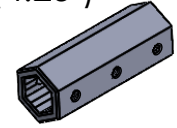

19: LONG LADDER LFOB



32: SHORT LADDER LRIT



20: LONG LADDER LFOT



33: SHORT LADDER LROT



25: LONG TUBE SPACER (5.625")

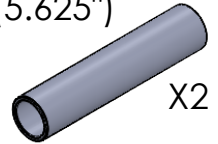

21: LONG LADDER RFIB



34: SHORT LADDER RFIT



26: SHORT TUBE SPACER (5.625")

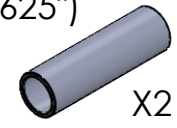

22: LONG LADDER RFIT



35: SHORT LADDER RFOT



23: LONG LADDER RFOB



36: SHORT LADDER RROT



24: LONG LADDER RFOT



37: SHORT LADDER RROT



X2

X2

38: LR RISER

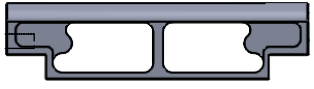

39: RF RISER

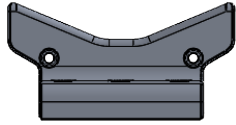

40: RR RISER



8: END CAPS X8

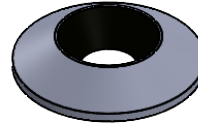

16: BLACK SPACER X 32



13: LONG CYLINDER SPACER (3.625")



15: SHORT CYLINDER SPACER (2.00")



1: 3/8 X 8 HEX HEAD SCREW



12: LONG CYLINDER SPACER W/GROOVES (3.79")

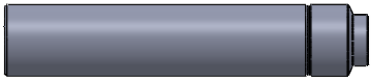

14: SHORT CYLINDER SPACER W/GROOVES (2.15")

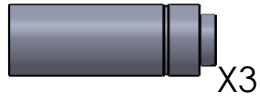

6: 3/8 X 6.5 HEX HEAD SCREW



10: CYLINDER BOLT SUPPORT BOTTOM (ROUND)

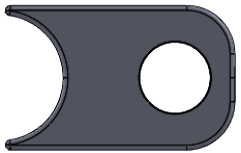

11: CYLINDER BOLT SUPPORT TOP (HEX)

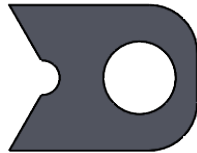

4: 5/16-18 X 2 SOCKET HEAD CAP SCREW

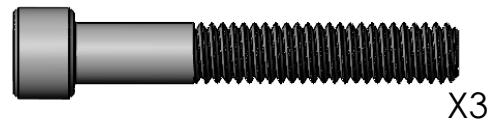

3: 5/16-18 X 1.25 SOCKET HEAD CAP SCREW



7: 1/4-20 X 5/8 FLAT HEAD CAP SCREW



5: 3/8 -16 LOCKNUT

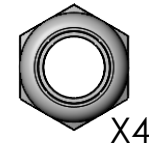

2: 5/16 - 18 NUT

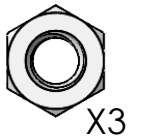

9: HYDRAULIC CYLINDERS



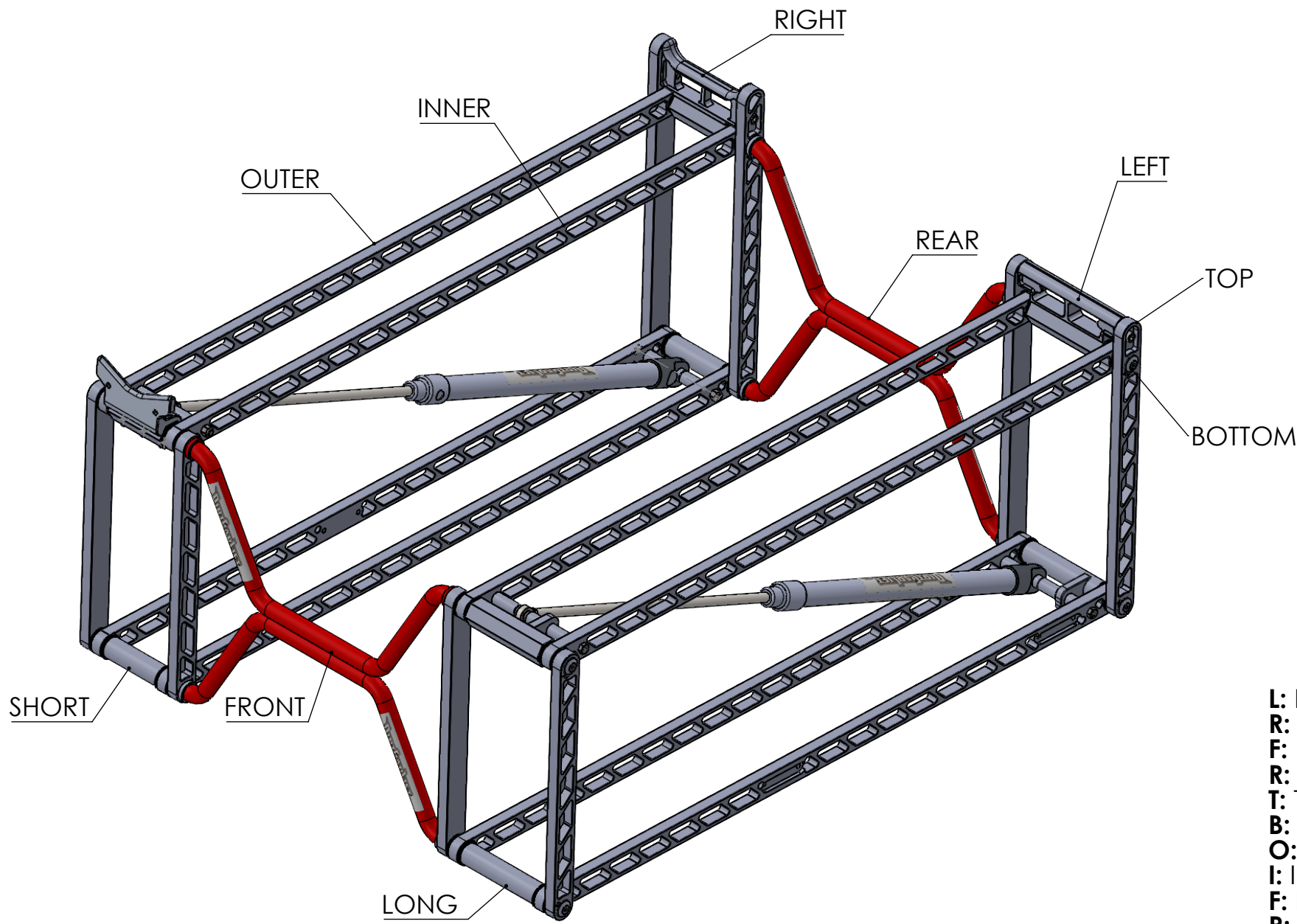

- L: LEFT
- R: RIGHT
- F: FRONT
- R: REAR
- T: TOP
- B: BOTTOM
- O: OUTER
- I: INNER
- F: FRONT
- R: REAR

EACH PART IS LABELED WITH THE SIDE AND DIRECTION THEY GO IN.  
**EXAMPLE:** LFIT - LEFT FRONT INNER TOP.  
 SHORT AND LONG LADDERS HAVE THE LABELS ENGRAVED ON THEM



## KEEP IN MIND:

- SHORT LADDERS AND LONG LADDERS LABELS FACE OUTER ASSEMBLY
- LONG LADDERS LABELS ARE ALWAYS IN THE FRONT DIRECTION
- SHORT LADDERS LABEL ARE ALWAYS ON THE TOP SIDE
- ALL PARTS LABELED SHORT GO ON THE RIGHT SIDE
- ALL PARTS LABELED LONG GO ON THE LEFT SIDE

## BEFORE YOU BUILD

- THIS DOES REQUIRE GREASE. ANY CHASSIS OR BEARING GREASE
- SORT PARTS TO MAKE IT EASIER TO ASSEMBLE
- GET ALL THE TOOLS YOU NEED
  - 1/4 ALLEN WRENCH KEY
  - 3/16 ALLEN WRENCH KEY
  - 5/32 ALLEN WRENCH KEY
  - 1/8 ALLEN WRENCH KEY
  - 1/2 WRENCH
  - 9/16 WRENCH
  - 1/4 WRENCH
  - RUBBER Mallet
  - FLATHEAD SCREWDRIVER ANY SIZE
- MAKE SURE YOU HAVE A CLEAN WORKSPACE
- BE SURE TO GREASE BLACK SPACERS AND LADDER OPENINGS

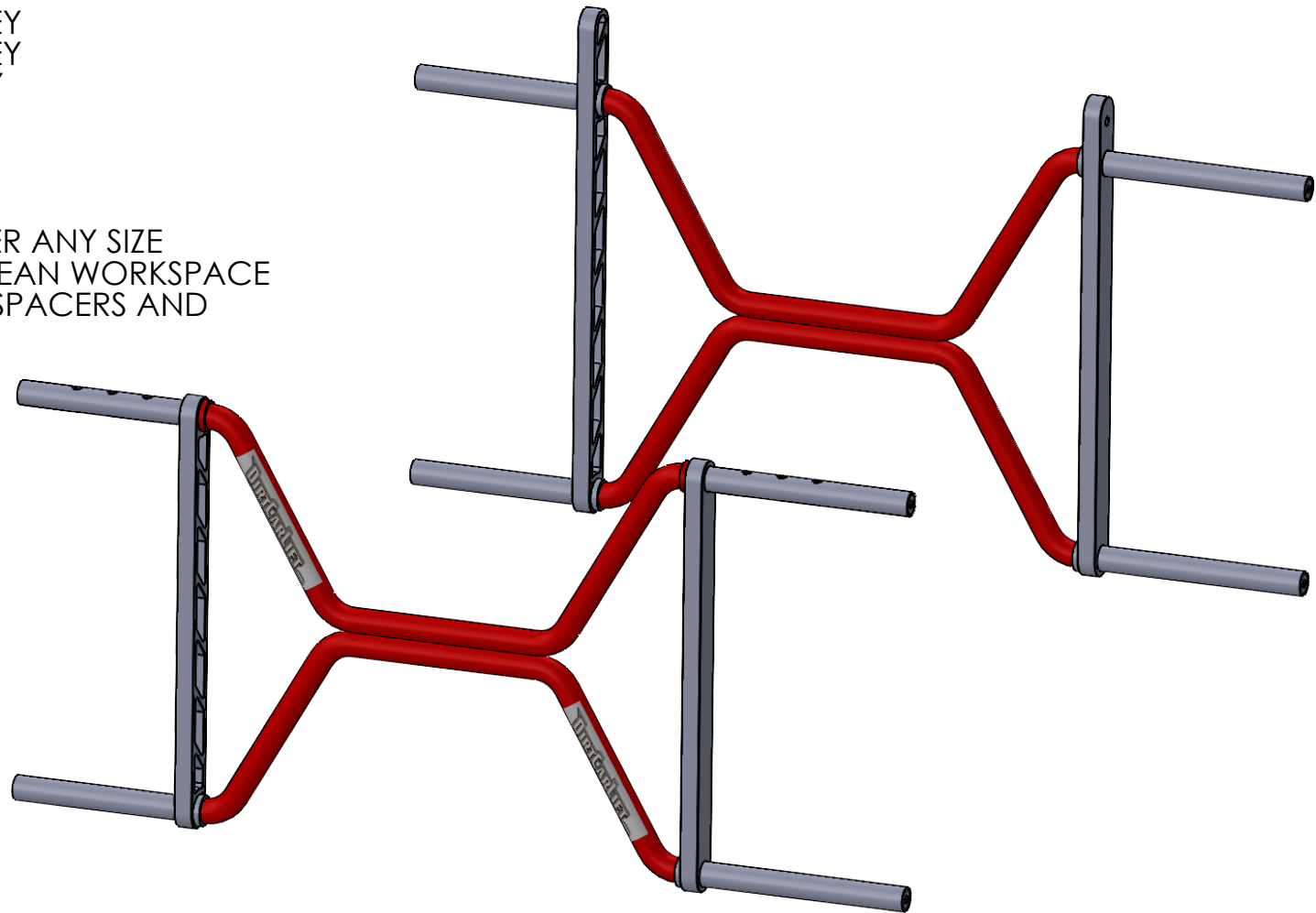

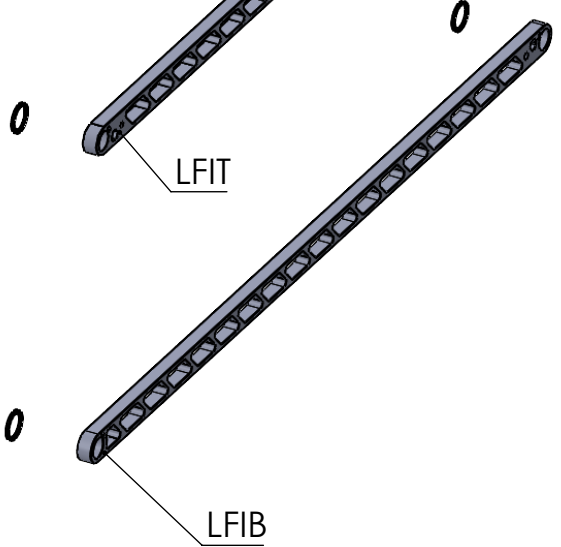
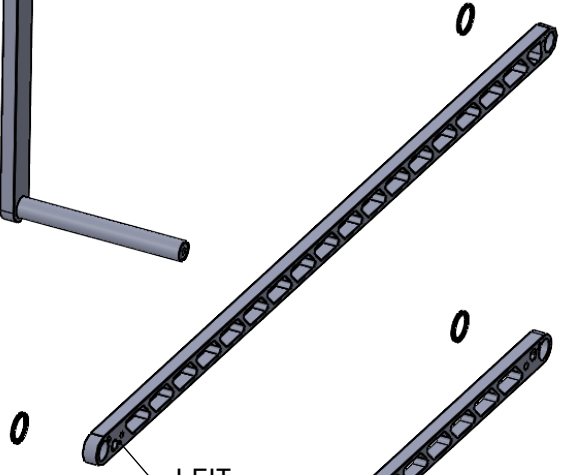
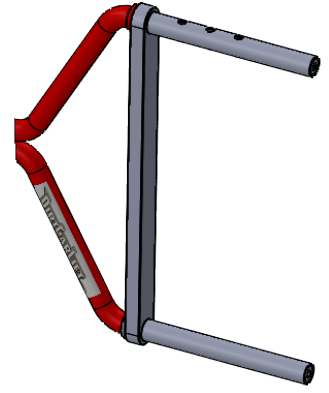
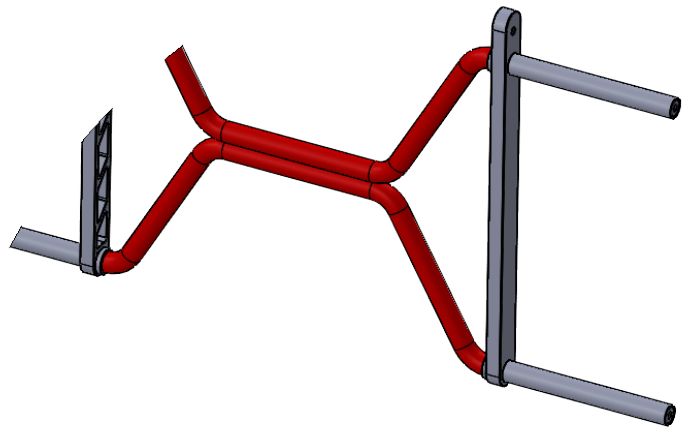

BLACK SPACER  
LONG LADDER (LFIT)  
LONG LADDER (LFIB)

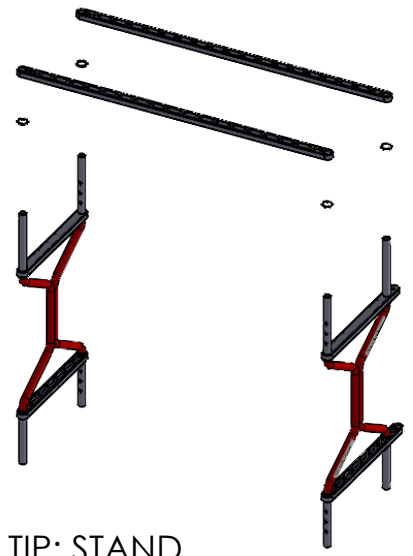
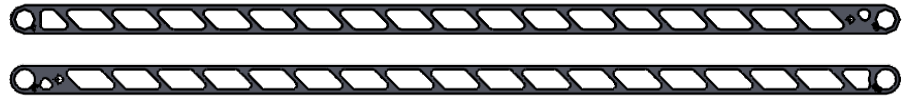

TIP: STAND  
ASSEMBLY UP AND  
ATTACH LONG  
LADDERS

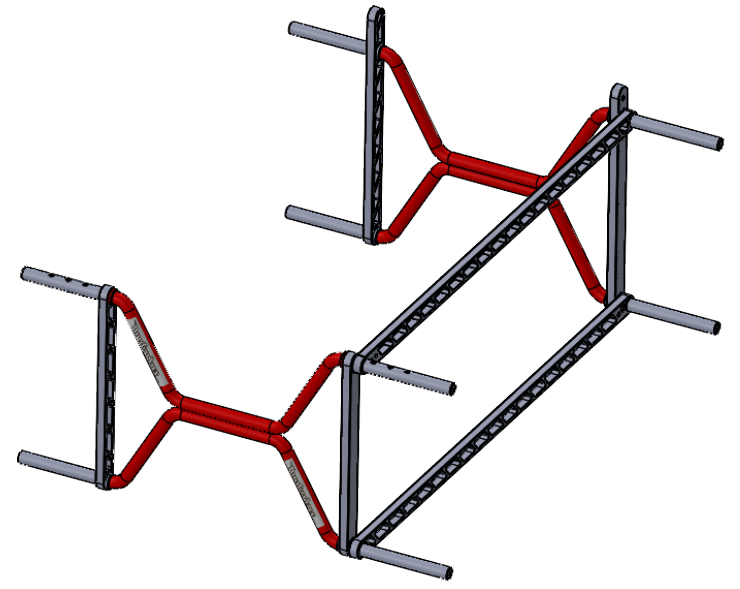

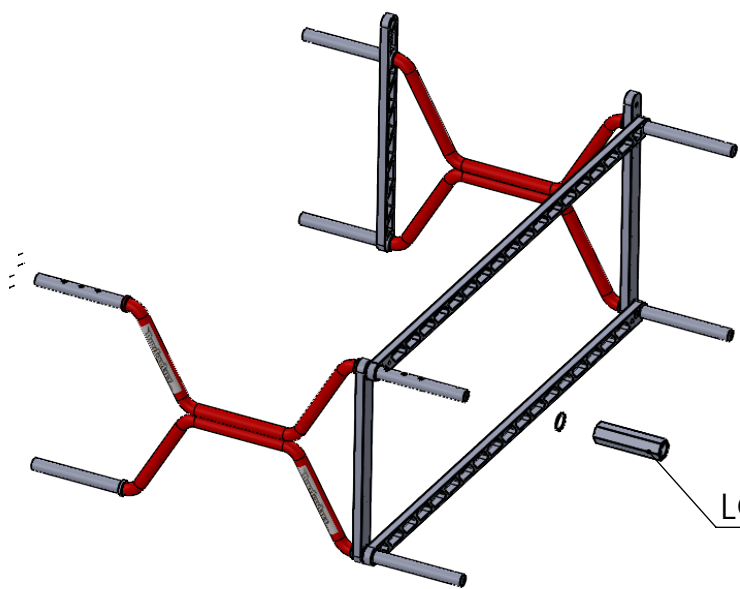

BLACK SPACER  
LONG HEX 5.625  
LONG TUBING SPACER 5.625

LONG HEX

LONG TUBING SPACER

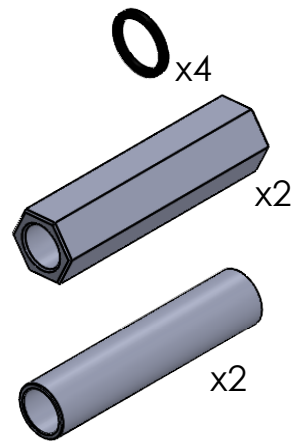

x4

x2

x2

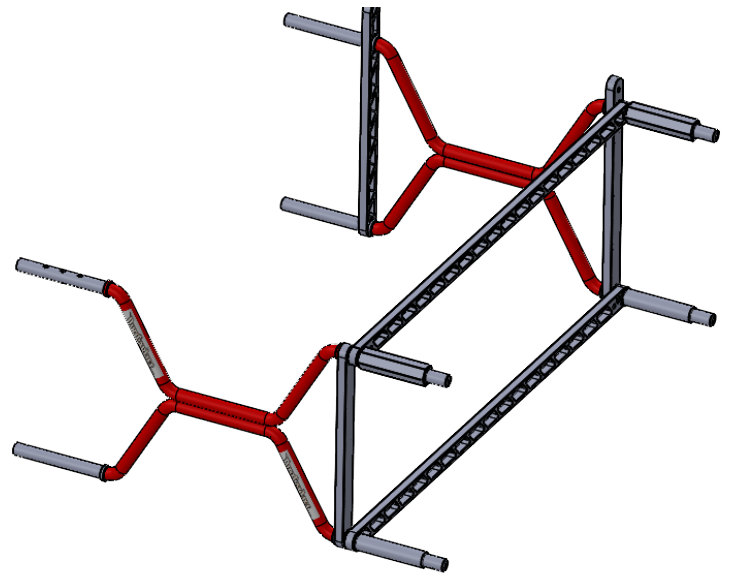
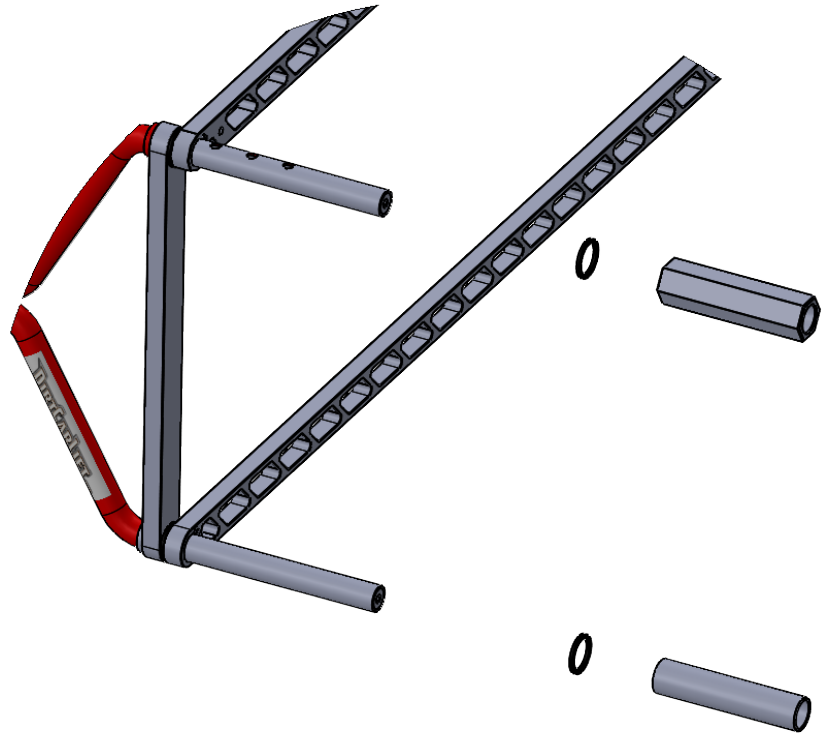

4

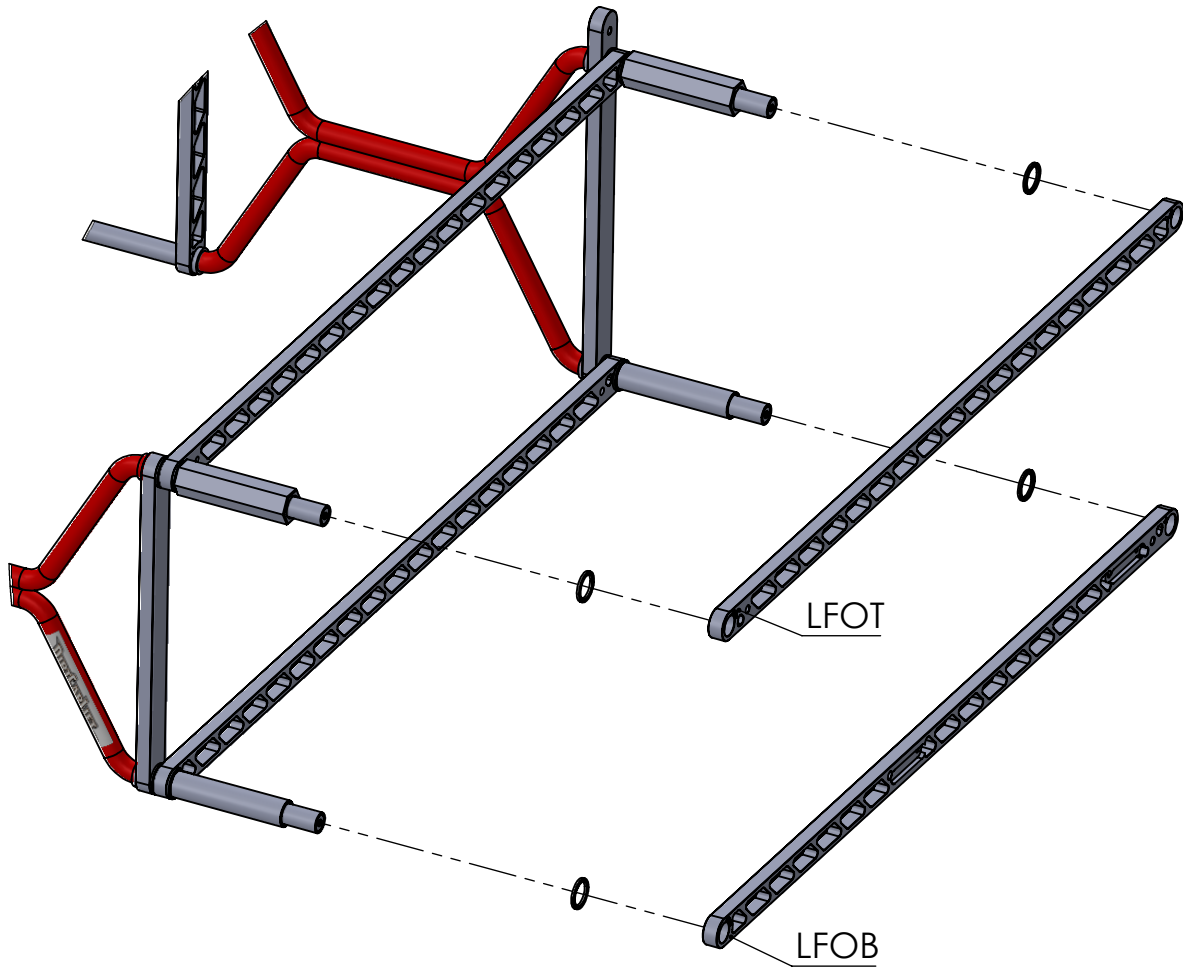

TIP: STAND ASSEMBLY UP AND ATTACH LONG LADDERS

BLACK SPACER  
LONG LADDER (LFOT)  
LONG LADDER (LFOB)



x4

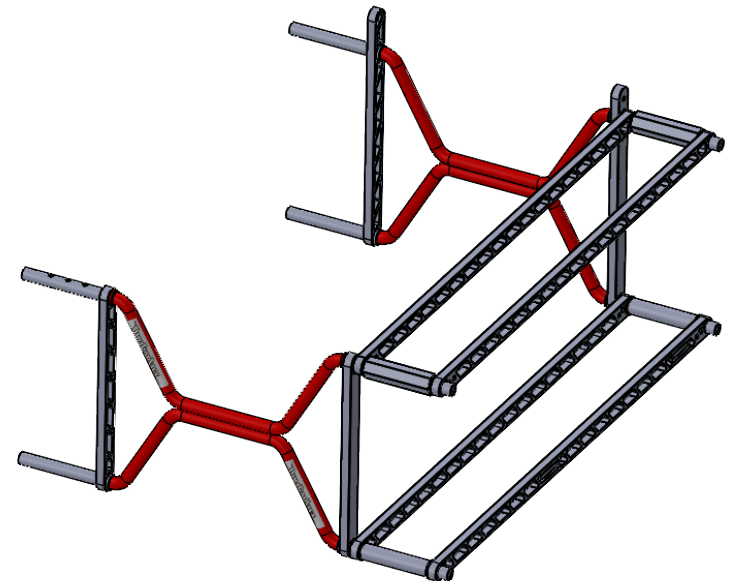
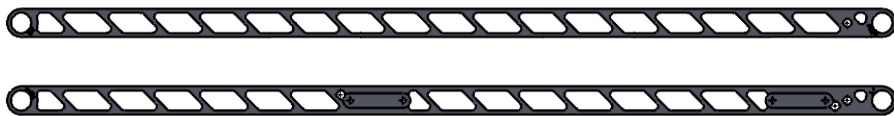

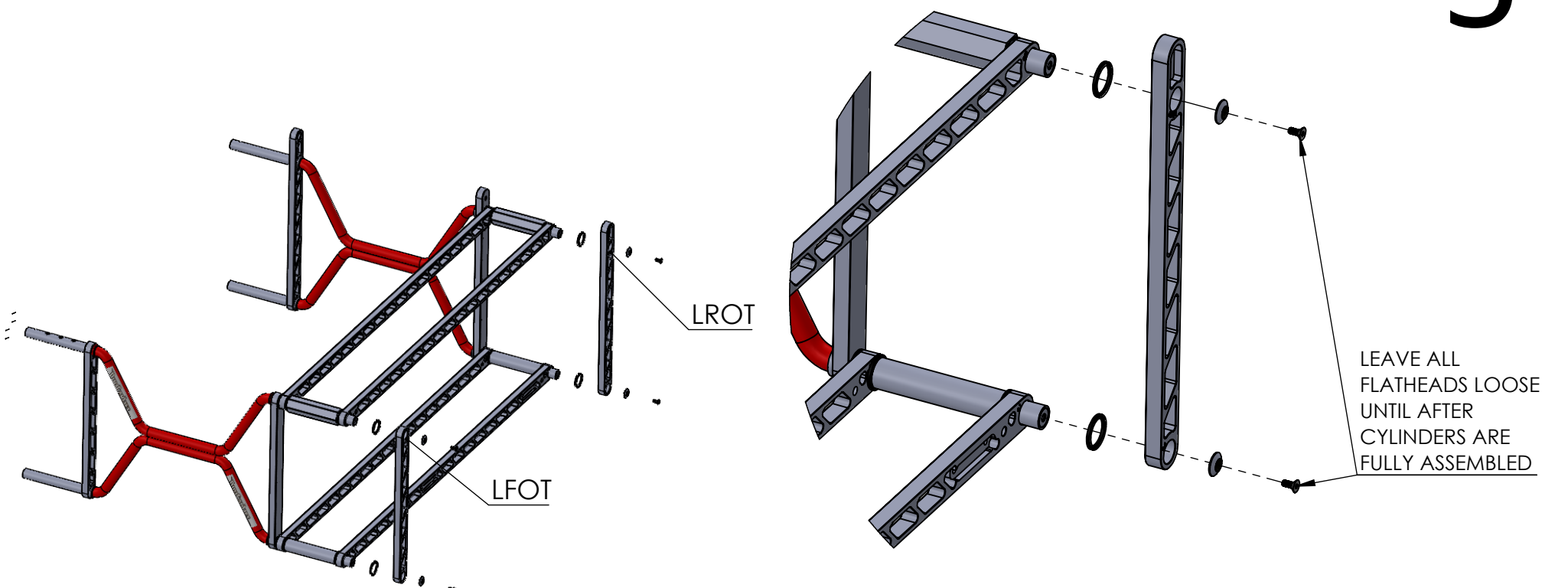

- BLACK SPACER
- ENDCAPS
- 1/4-20X5/8 FLAT HEAD SCREW (1:1 SCALE)
- SHORT LADDER (LFOT)
- SHORT LADDER (LROT)

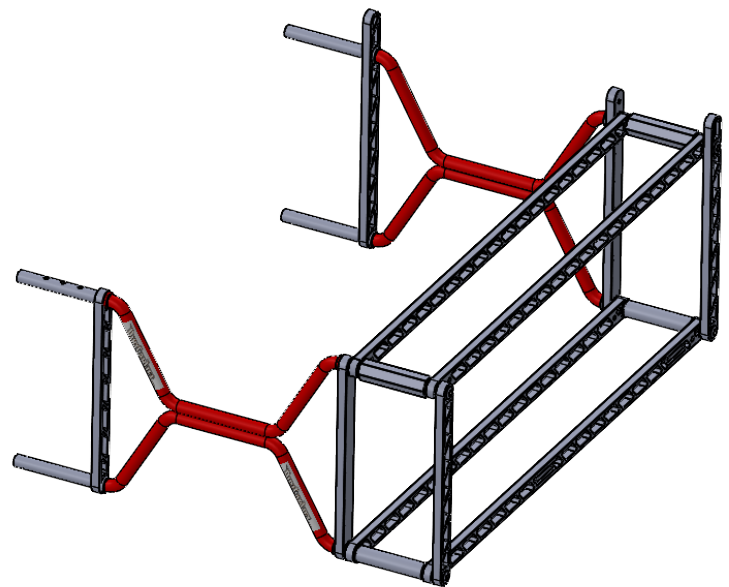
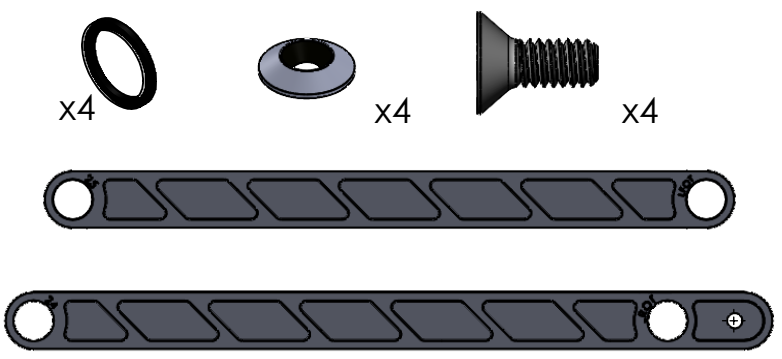

ADD **RED** THREAD LOCKER TO SCREWS

MAKE TOP OF HEX AND BOTTOM OF RISER FLUSH

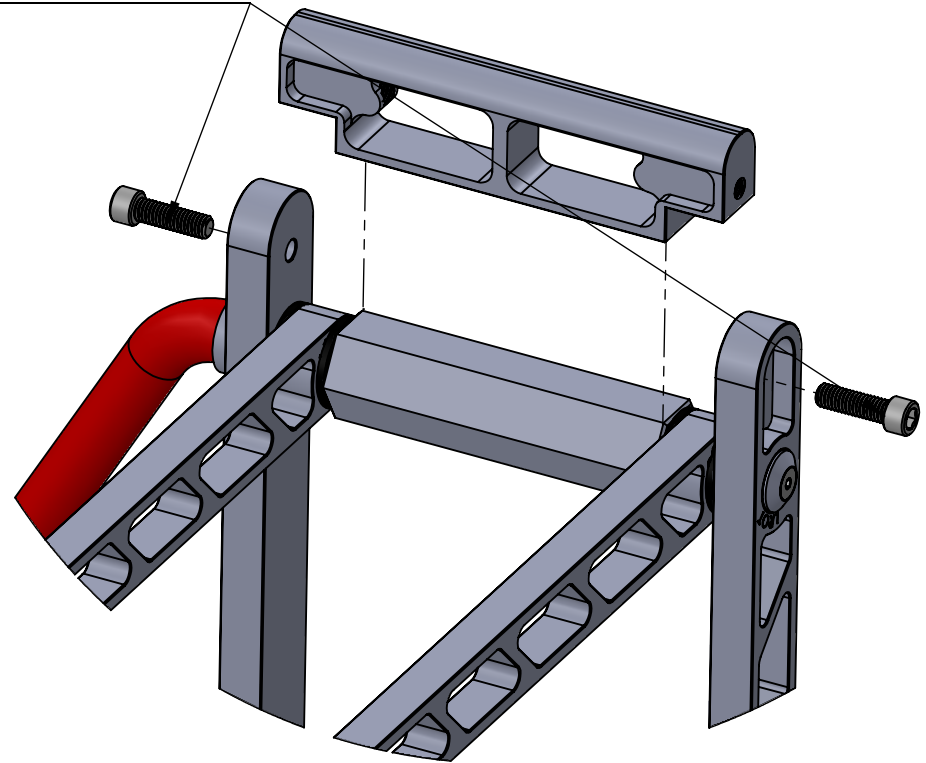
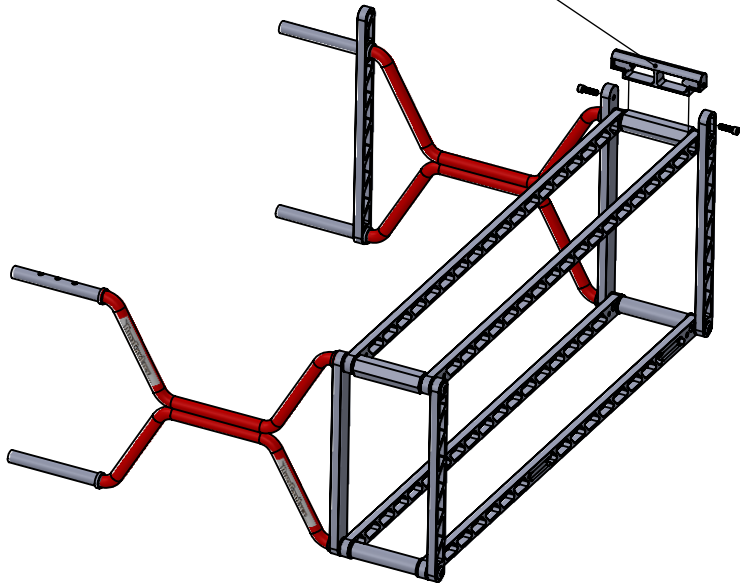

5/16X1.25 SOCKET HEAD SCREW 1:1 SCALE LR RISER

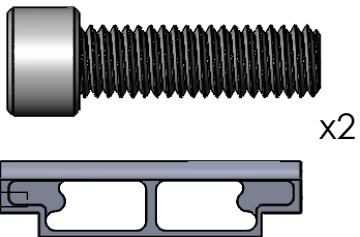

x2

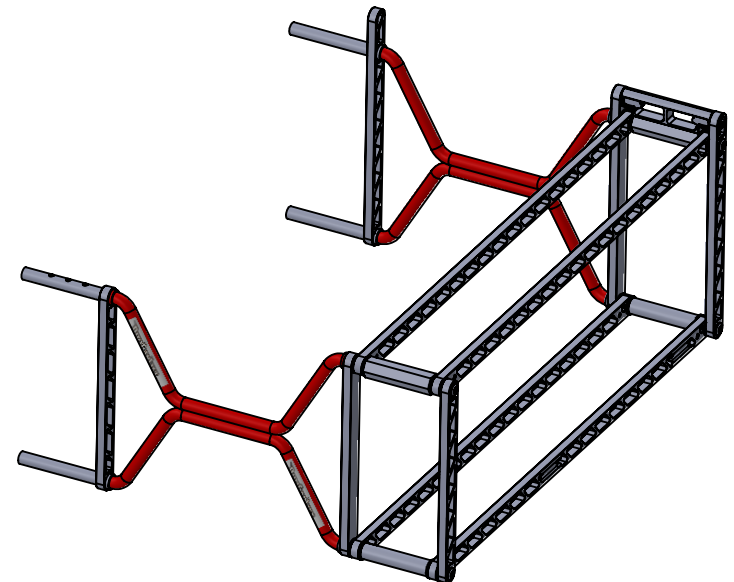

7

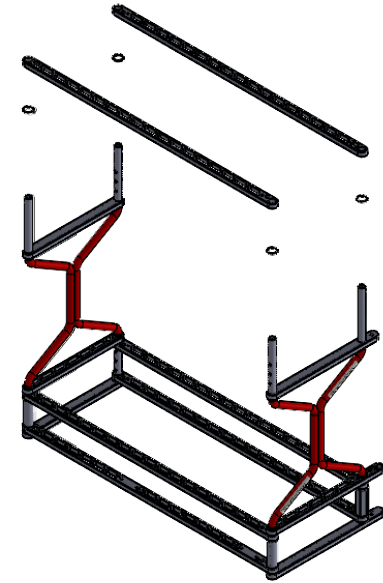
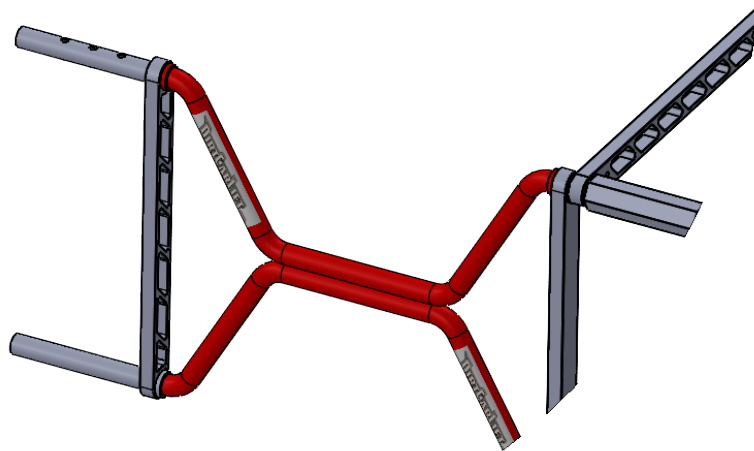
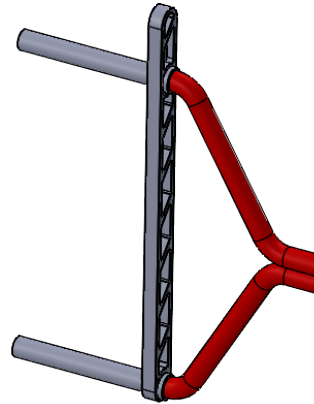
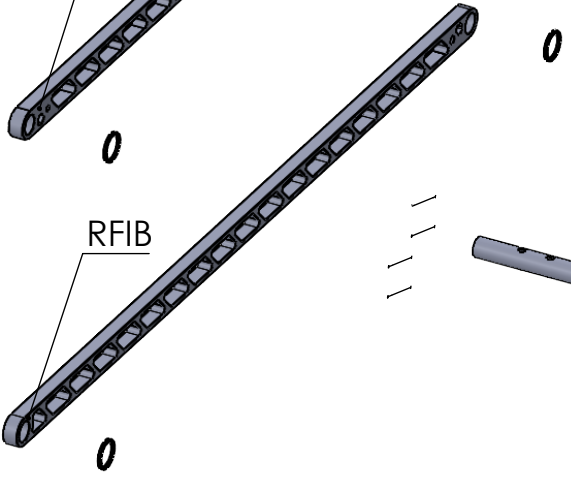
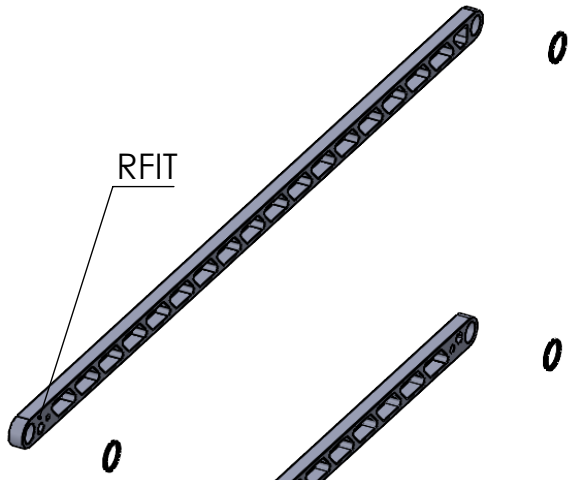

TIP: STAND ASSEMBLY UP AND ATTACH LONG LADDERS

BLACK SPACER  
LONG LADDER (RFIT)  
LONG LADDER (RFIB)

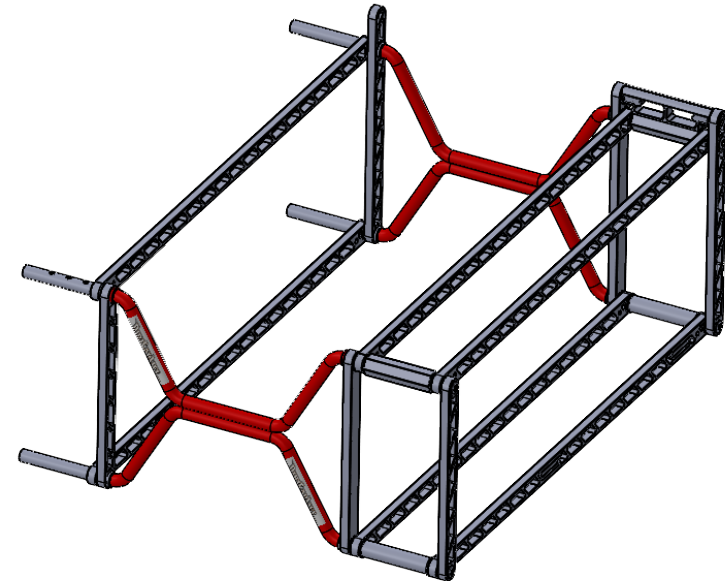
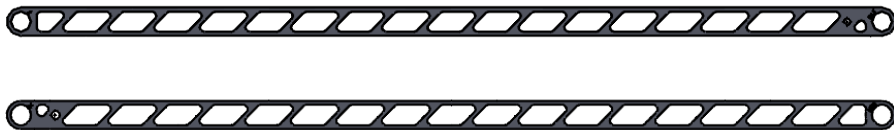
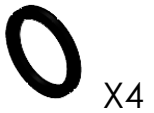

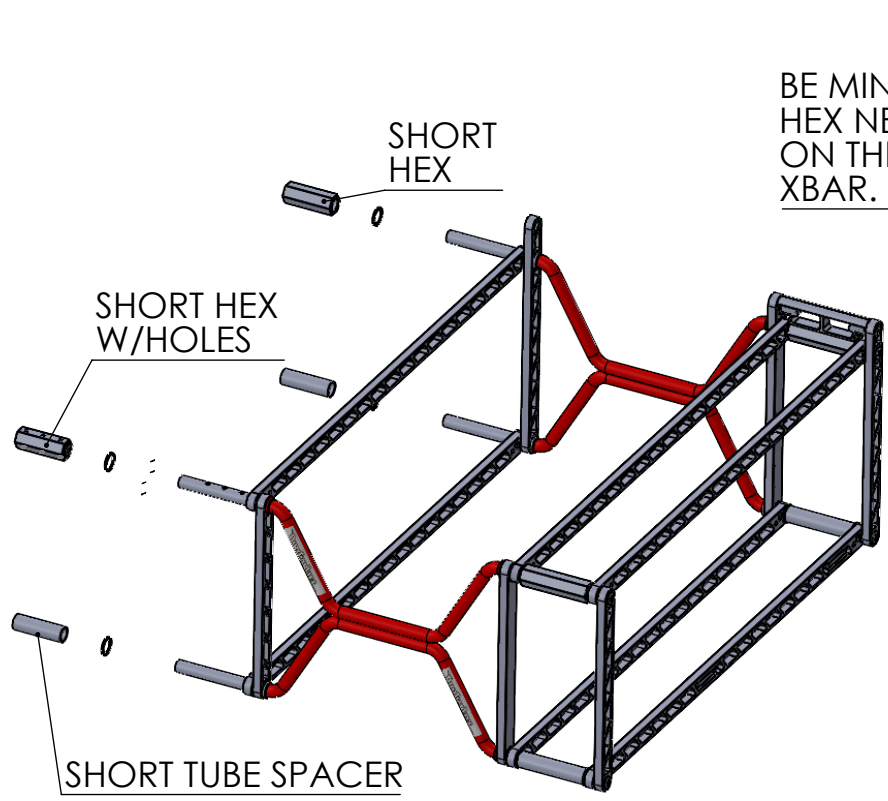

BE MINDFUL THAT THIS HEX NEEDS TO BE PUT ON THIS SIDE OF THE XBAR.

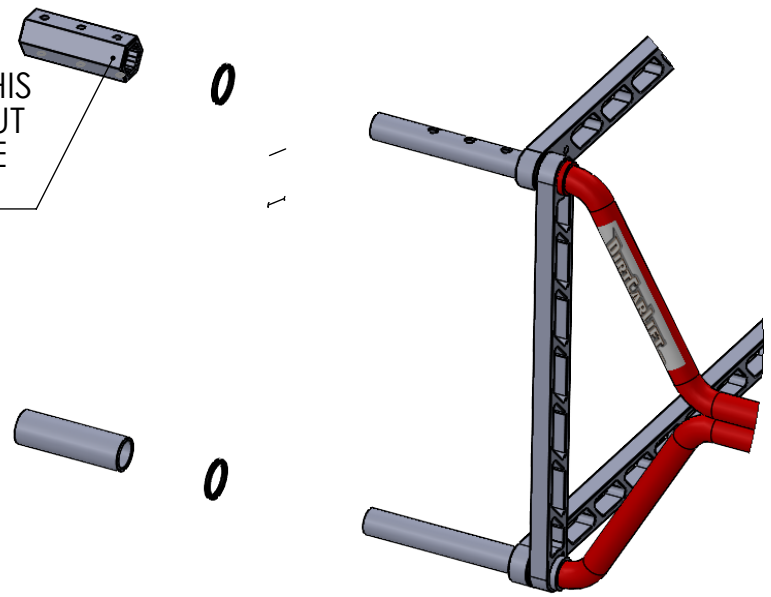

BLACK SPACER  
SHORT HEX W/HOLES 4.25"  
SHORT HEX 4.25"  
SHORT TUBE SPACER 4.25"

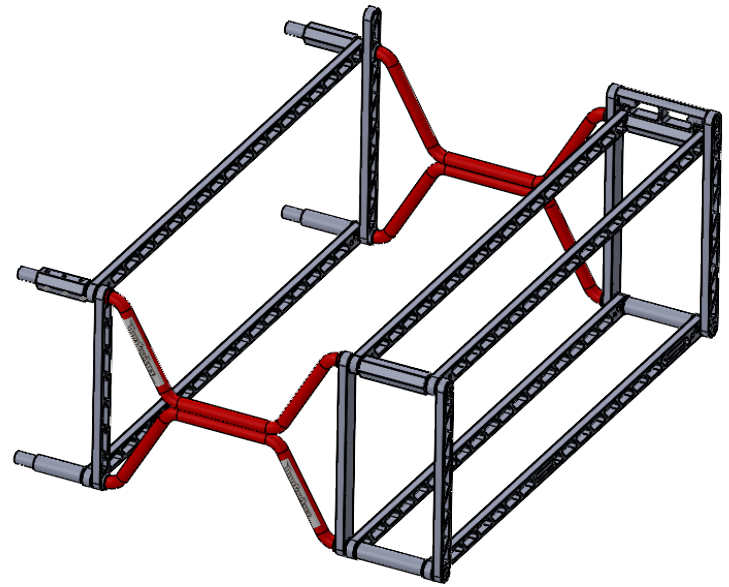
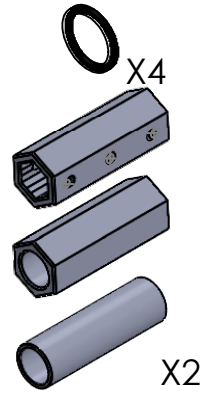



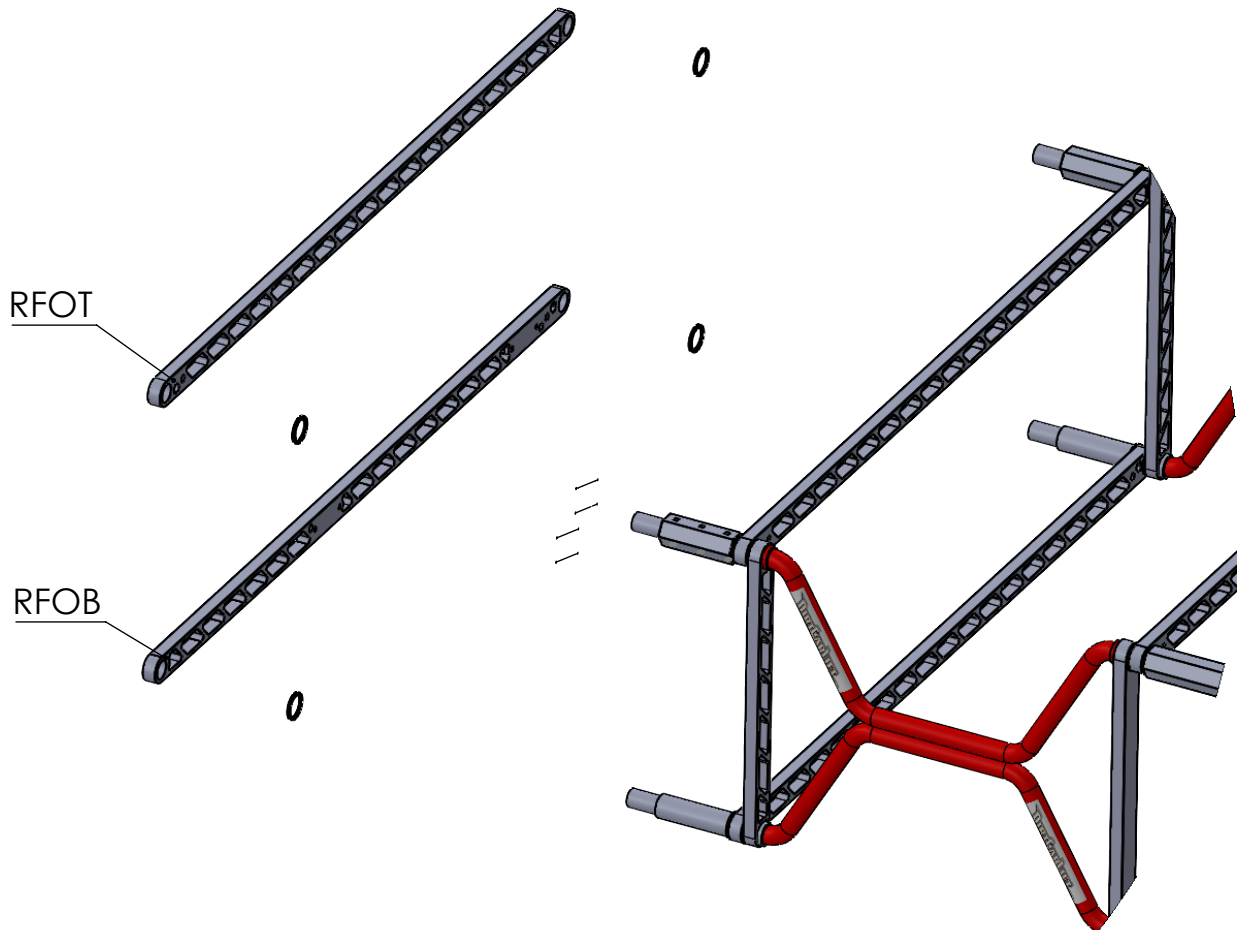

RFOT

RFOB

BLACK SPACER  
LONG LADDER (RFOT)  
LONG LADDER (RFOB)

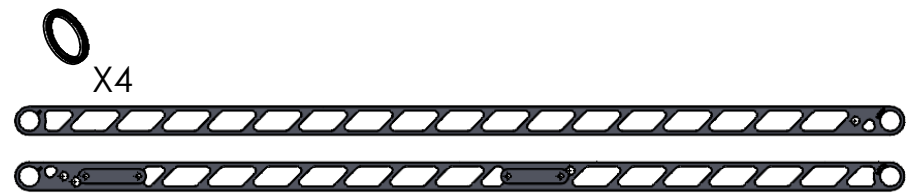

X4

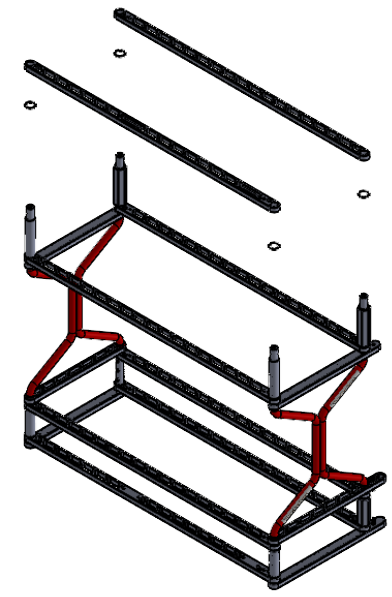

TIP: STAND ASSEMBLY  
UP AND ATTACH  
LONG LADDERS

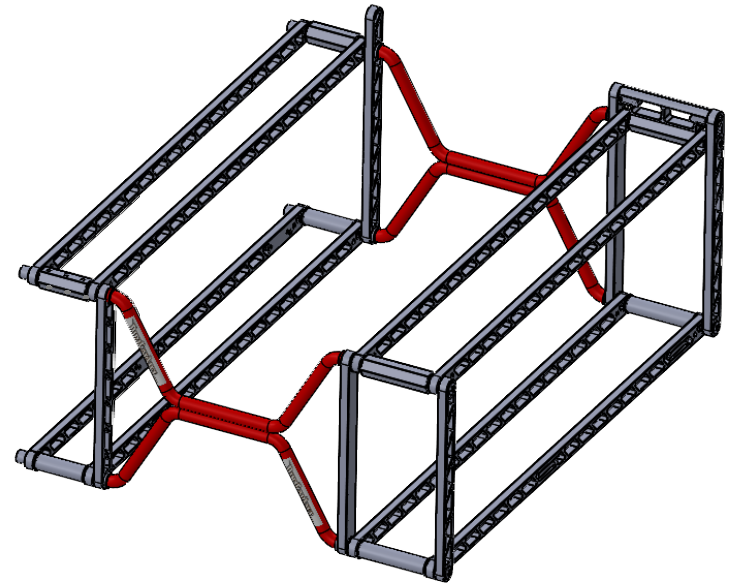

LEAVE ALL FLATHEAD  
LOOSLY UNTIL AFTER  
CYLINDERS ARE FULLY  
INSTALLED

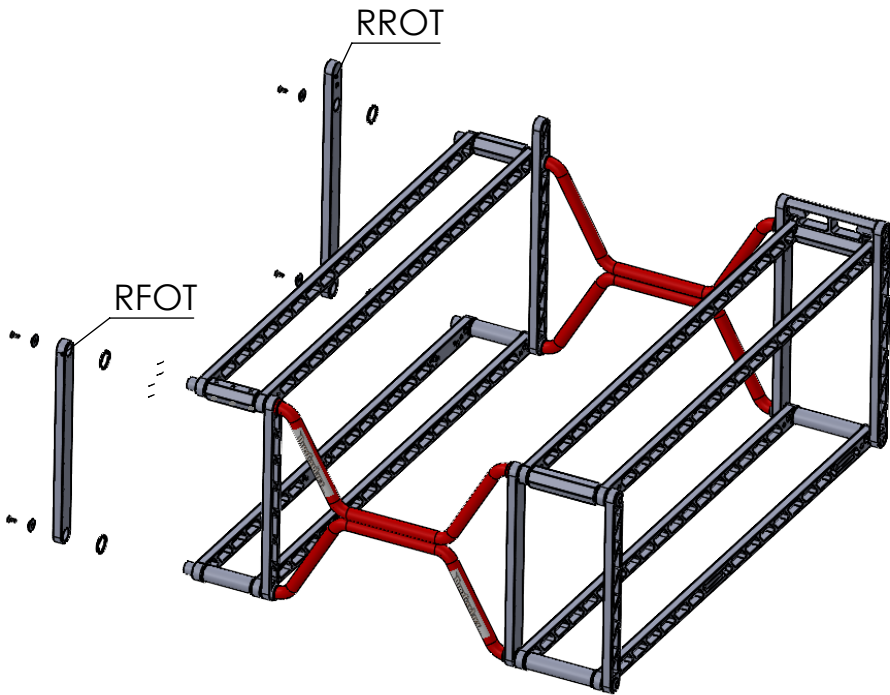

BLACK SPACER  
ENDCAPS  
1/2-20X5/6 FLAT HEAD SCREW (1:1 SCALE)  
SHORT LADDER (RROT)  
SHORT LADDER (RFOT)

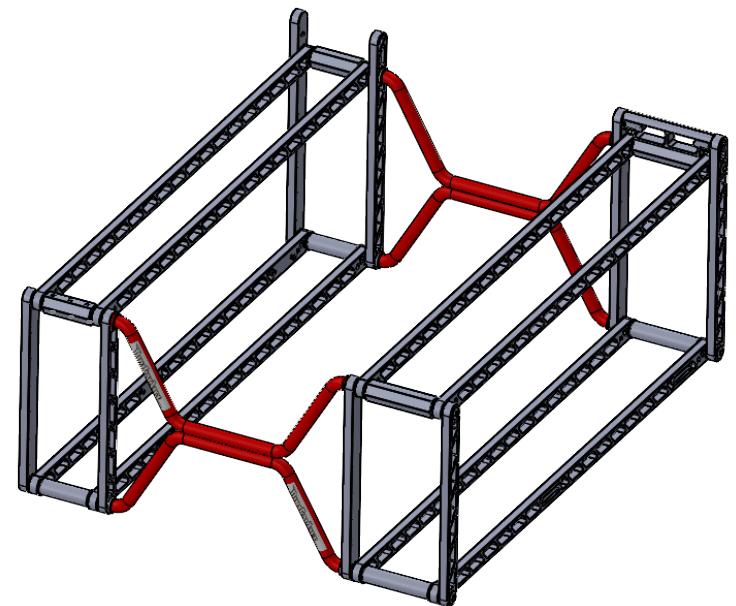
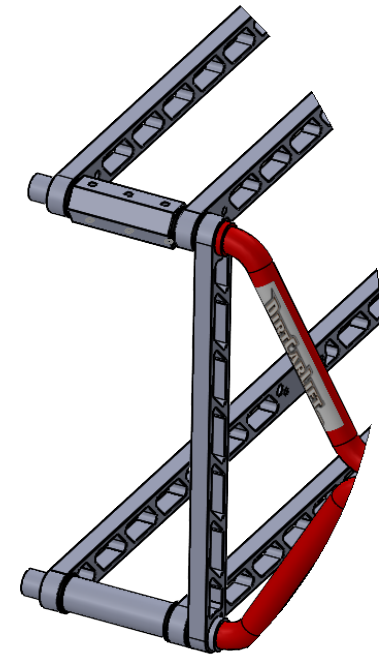
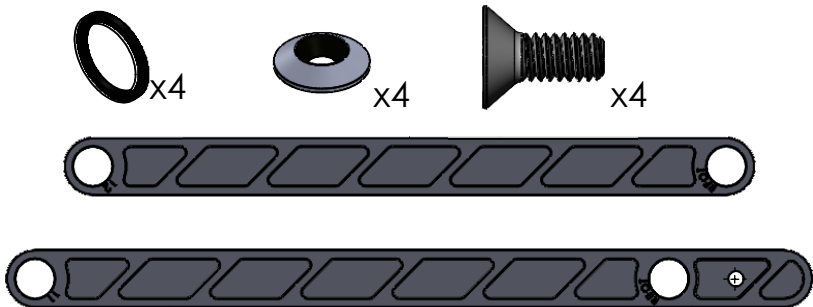

ALL HOLES LINE UP FOR THE CAP NUT

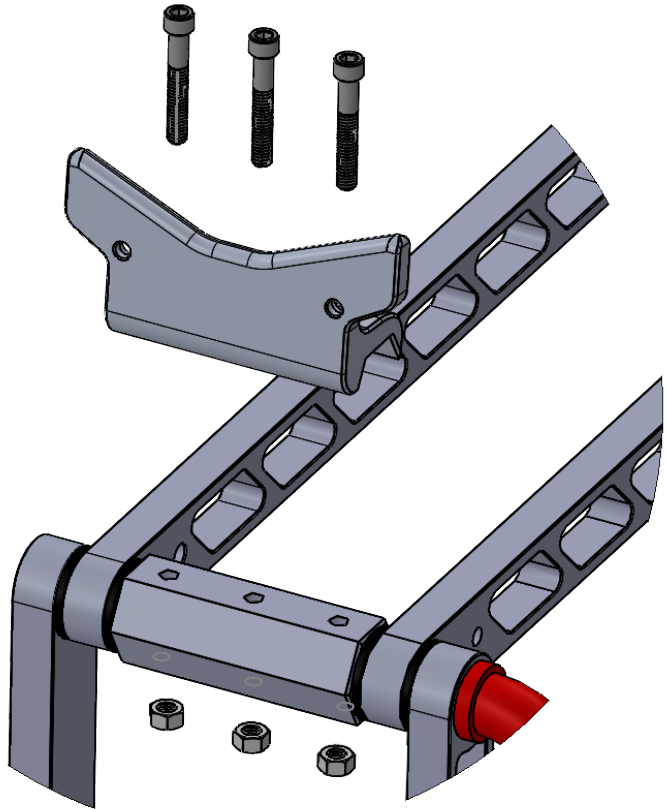
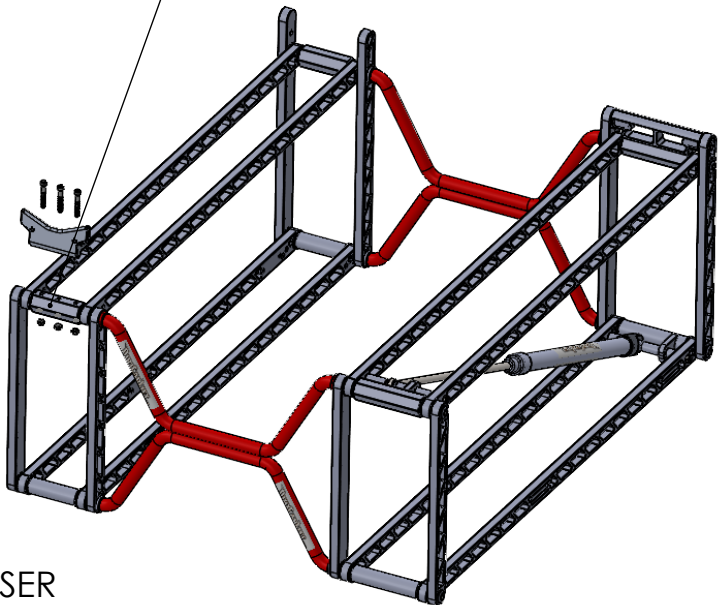

RF RISER  
5/16-18X2 SOCKET HEAD  
CAP NUT (1:1 SCALE)  
5/16-18 NUT (1:1 SCALE)

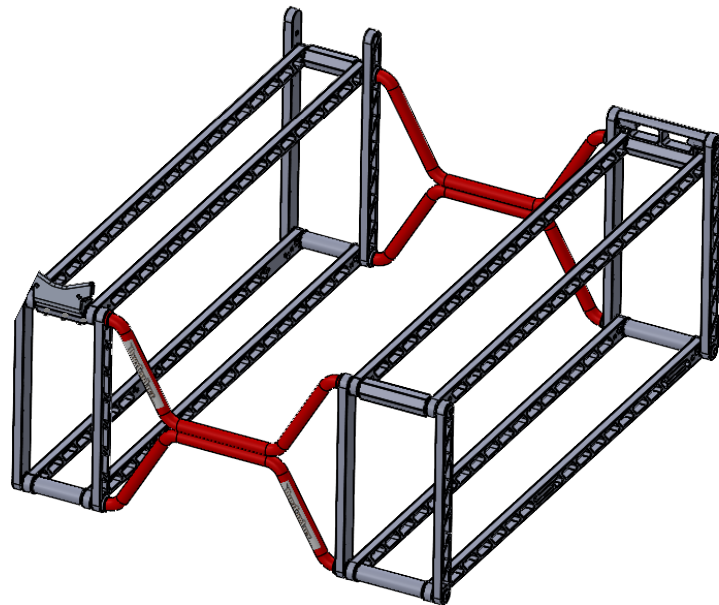
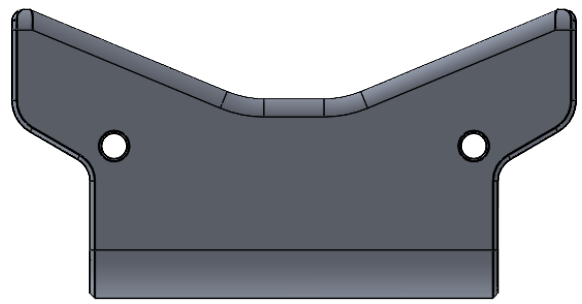

ADD **RED** THREAD LOCKER

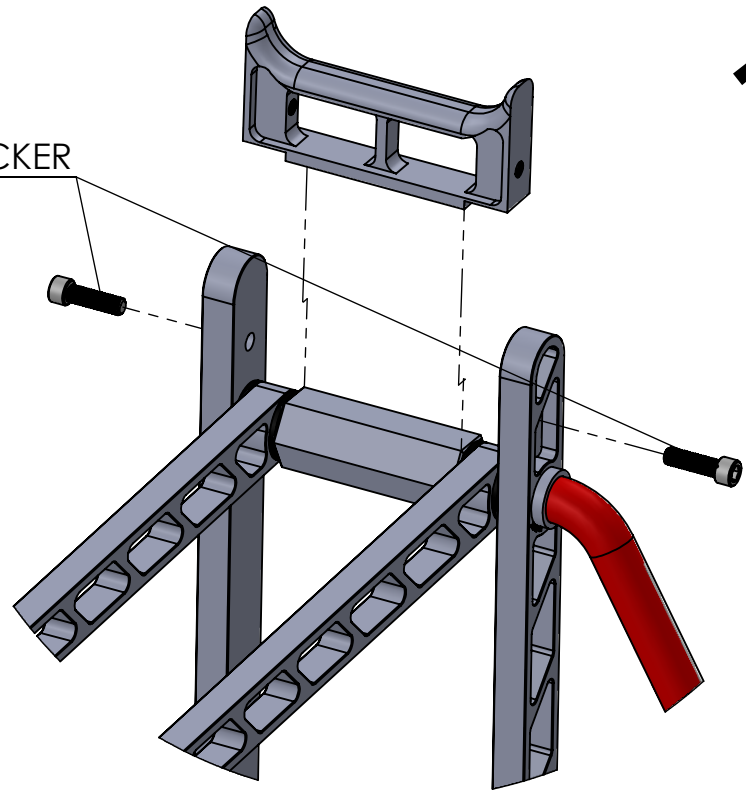
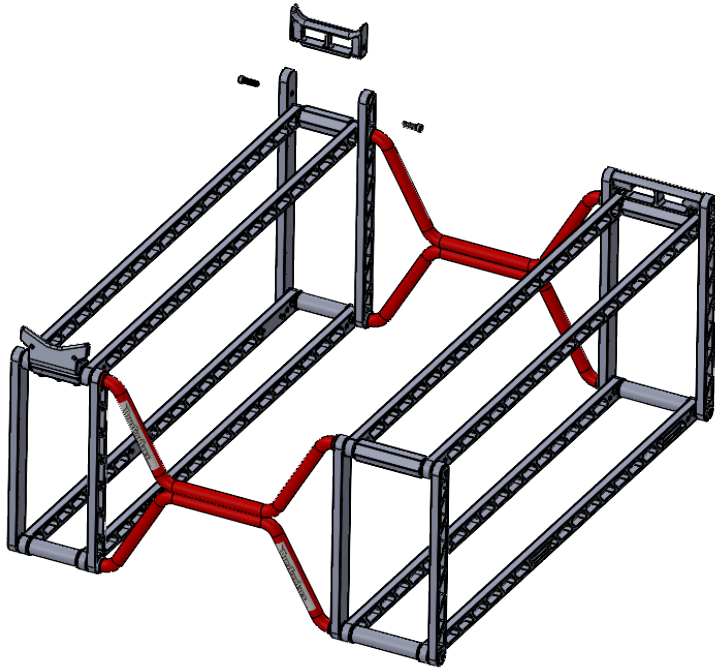

5/16-18X1.25 SOCKET HEAD  
CAP SCREW(1:1 SCALE)  
RR RISER

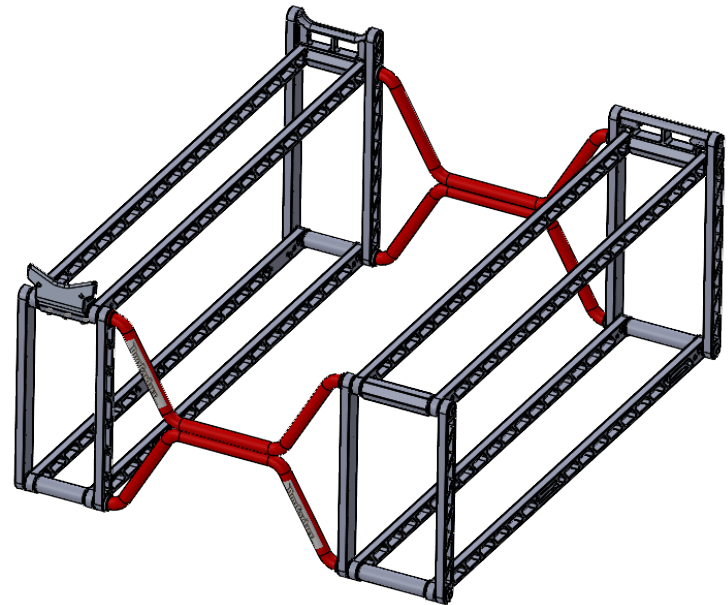

LAY ASSEMBLY FLAT BEFORE INSTALLING HYDRAULICS

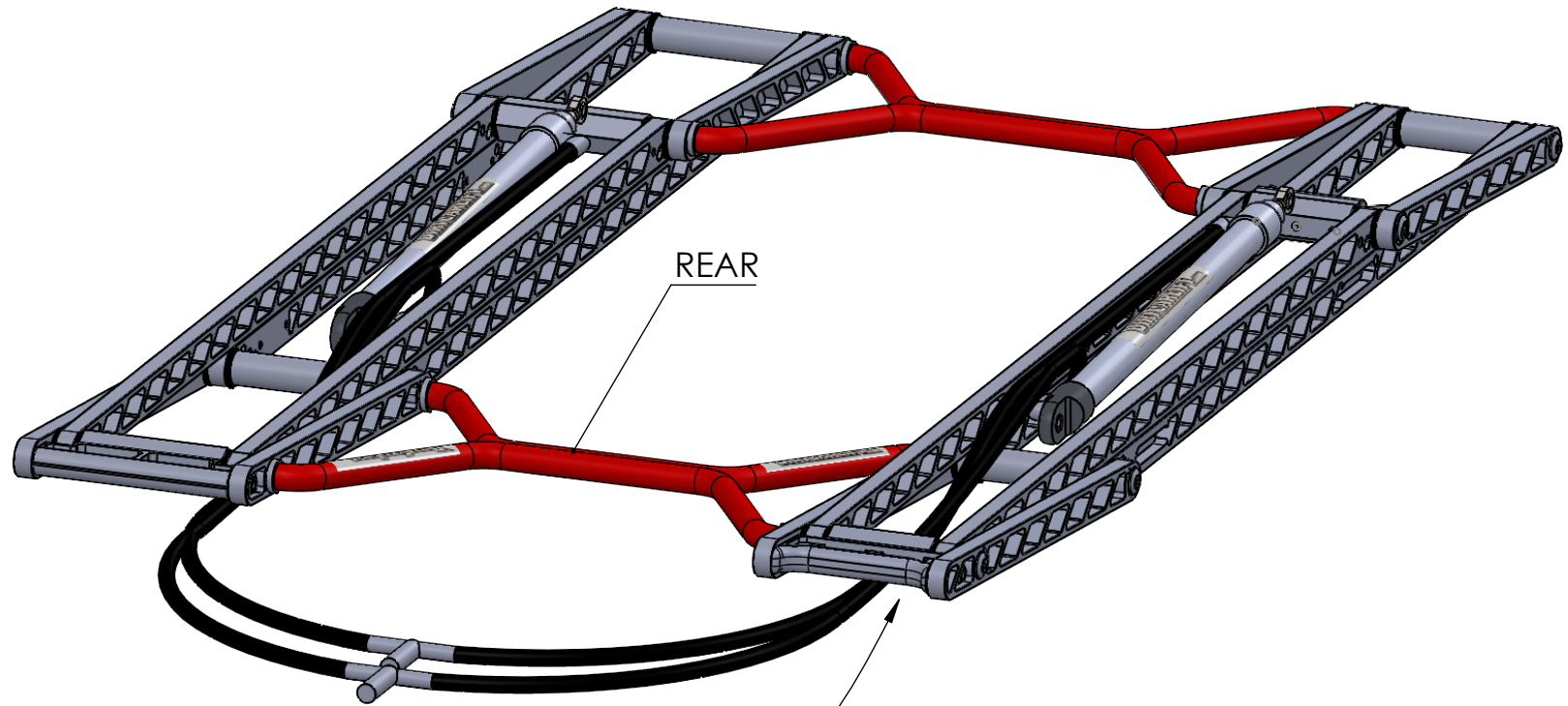

REAR

SLIDE CYLINDER  
THROUGH OPENING

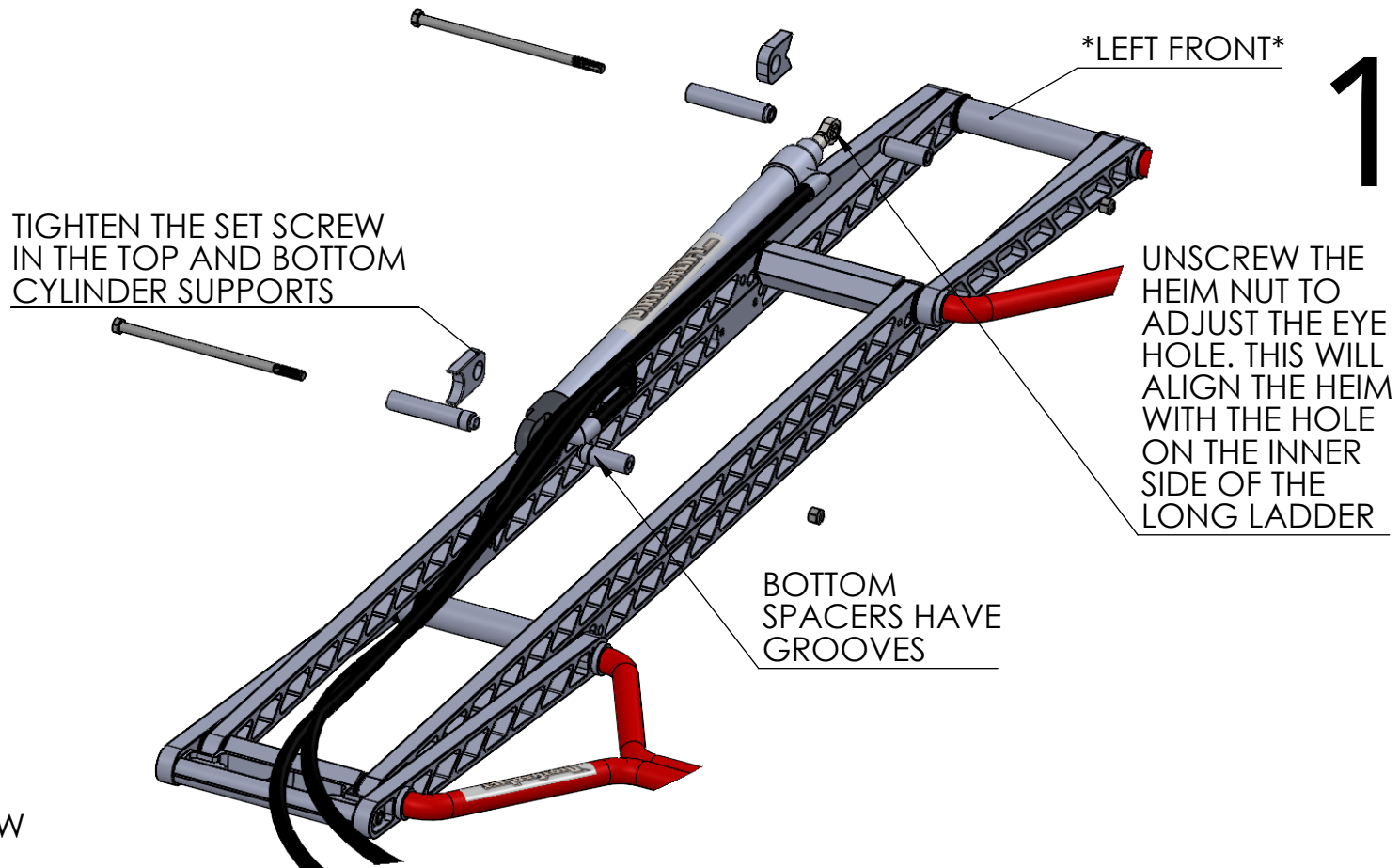

- 3/8" HEX HEAD SCREW
- 3/8-16 LOCKNUT
- CYLINDER BOLT SUPPORTS BOTTOM
- CYLINDER BOLT SUPPORTS TOP
- LONG CYLINDER SPACER (W/GROOVES) 3.79 inches"
- LONG CYLINDER SPACER 3.625"
- SHORT CYLINDER SPACER (W/GROOVES) 2.15 inches"
- SHORT CYLINDER SPACER 2.00"
- HYDRAULIC CYLINDERS

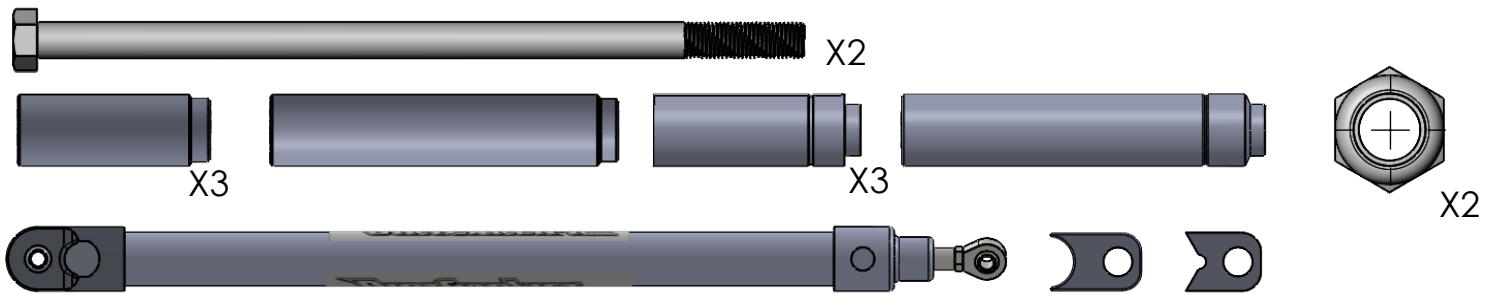

UNSCREW THE HEIM NUT TO ADJUST THE EYE HOLE. THIS WILL ALIGN THE HEIM WITH THE HOLE ON THE INNER SIDE OF THE LONG LADDER

RIGHT FRONT

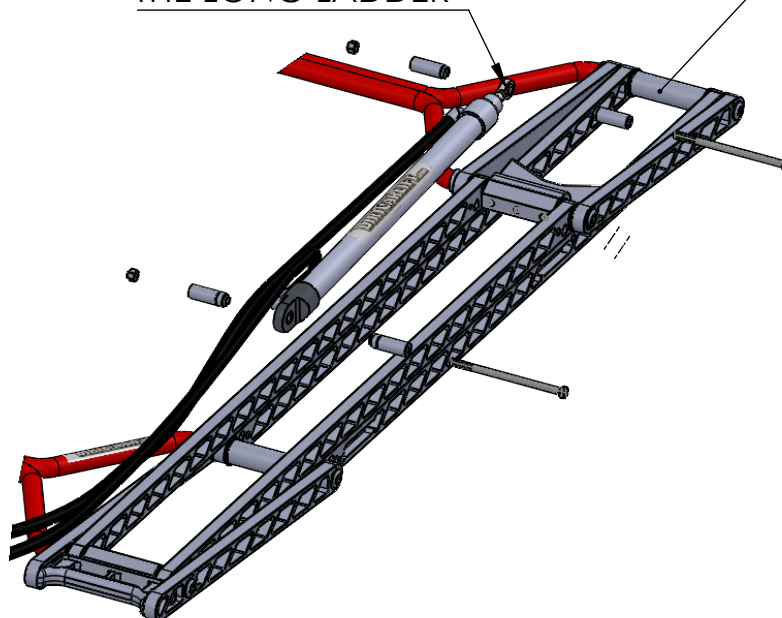

3/8"X6.5"HEX HEAD SCREW  
3/8-16 LOCKNUT  
SHORT CYLINDER SPACER (W/GROOVE) 2.15"  
SHORT CYLINDER SPACER 2.0"  
HYDRAULIC CYLINDERS



X2



X2



X2



X2

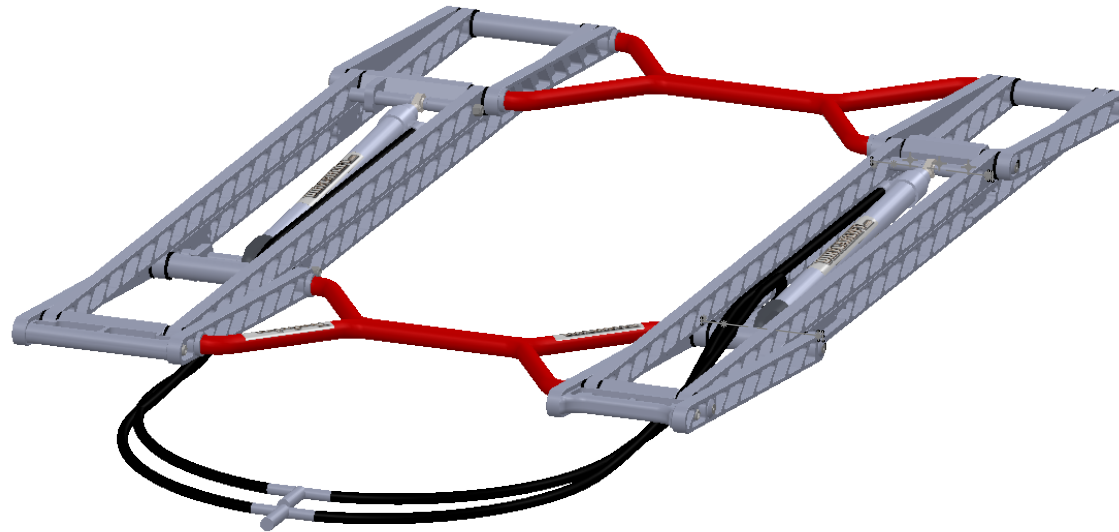

\*APPLY **RED** THREAD LOCK TO ENDCAP BOLTS AND TIGHTEN  
STEP FIVE AND TEN\*



# HANDLE BAR

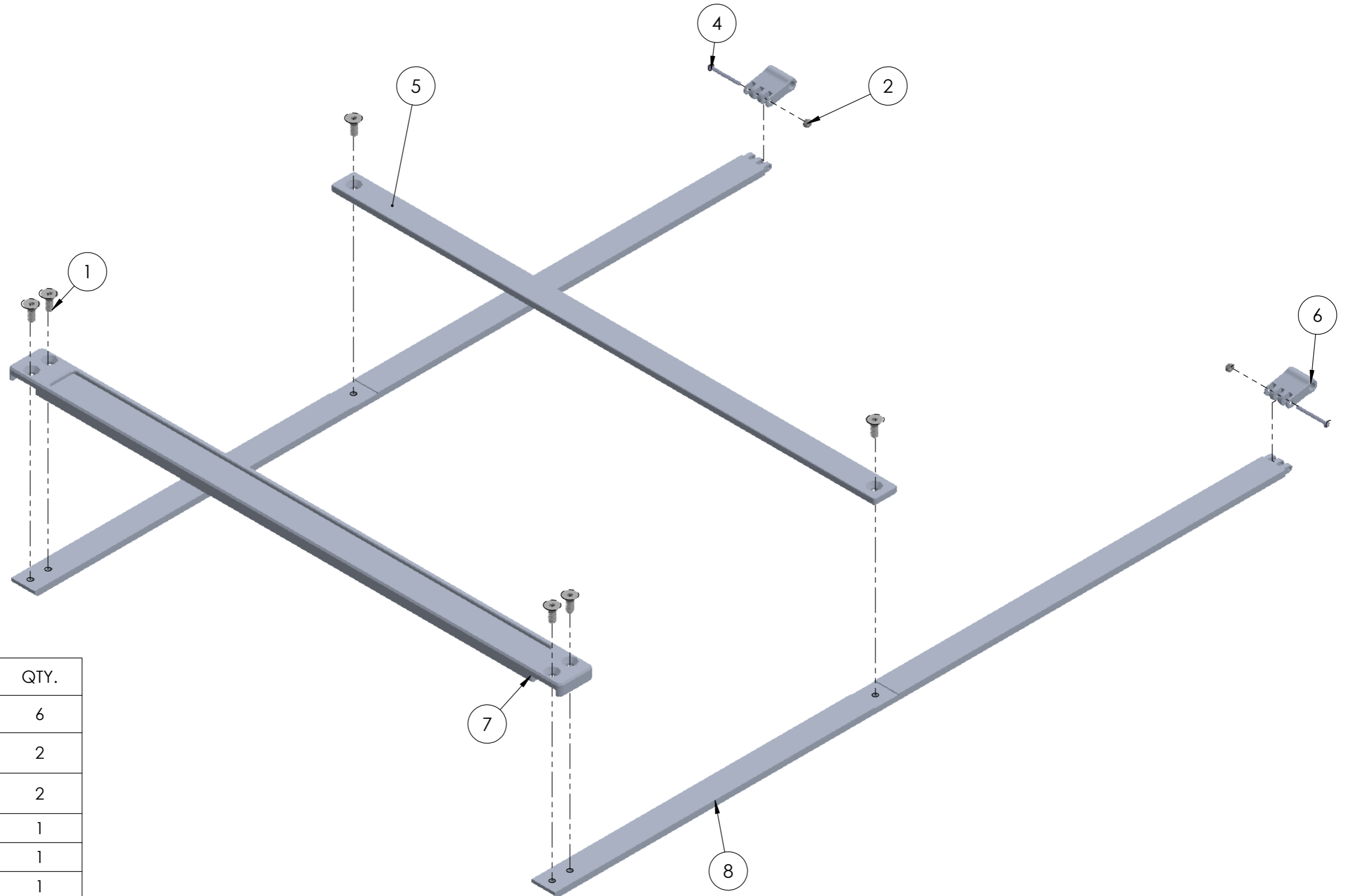

ITEM NO.	PART NUMBER	QTY.
1	1/4-20 X 5/8 FLAT HEAD CAP SCREW	6
2	5-40 JAM NUT	2
4	BRASS ROUND HEAD SLOTTED SCREW	2
5	CROSSBAR	1
6	DOGBONE	1
7	HANDLE BAR	1
8	HNDSTRAP	2

# HANDLE ASSEMBLY

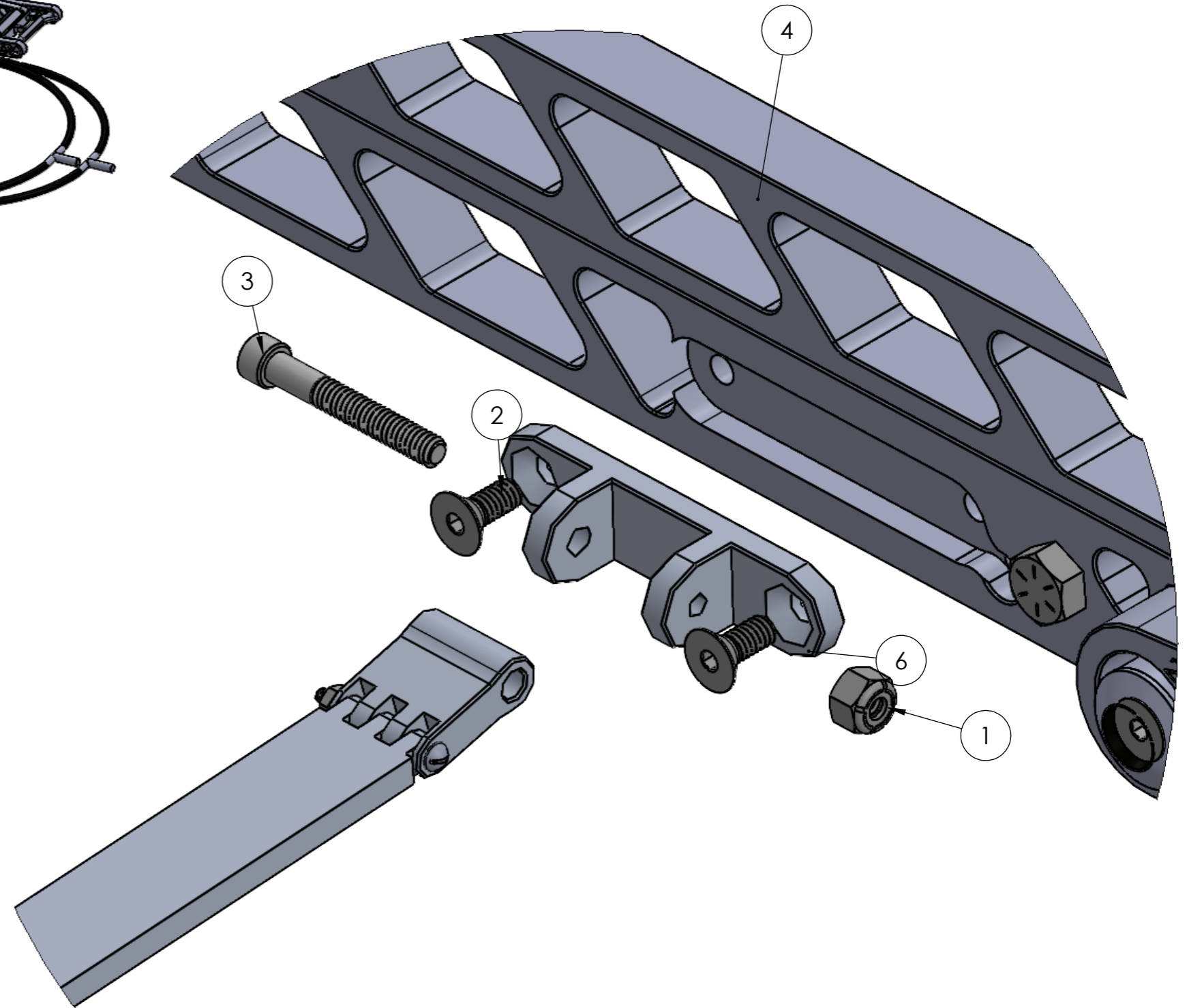
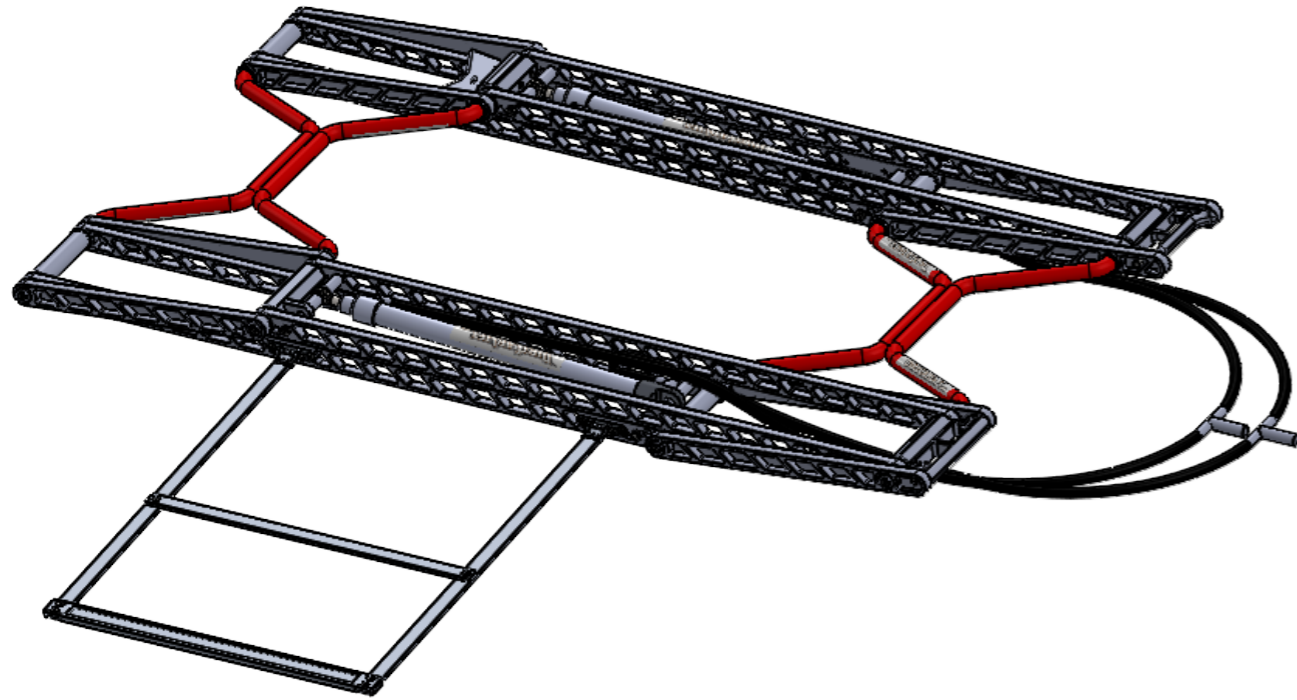

ITEM NO.	PART NUMBER	QTY.
1	1/4-20 JAM NUT	2
2	1/4-20 X 5/8 FLAT HEAD CAP SCREW	4
3	1/4-20X1-3/4 SOCKET HEAD CAP SCREW	2
4	DIRTCARLIFT	1
5	HANDLE	1
6	HANDLE BASE	2



## **BATTERY SPECIFICATIONS**

LENGTH; 7.75" WIDTH 5.125" HEIGHT: 7.25"

CRANKING AMPS; 430

CCA; 340-350

BATTERIES PLUS PART # **SLADC12-35J**

NAPA PART # **BAT 8227**

ADVANCE AUTO PART **U1-2**

HYDRAULIC OIL 1-GALLON PREMIUM CLEAR  
AW32 OR BETTER

**DO NOT USE** ATF (AUTOMATIC TRANSMISSION  
FLUID) OR ANY RED FLUID OF ANY TYPE  
THIS WILL VOID THE WARRANTY ON THE  
CYLINDERS/ PUMP/ HOSES /ETC.

## **FAQ**

### **WHAT ARE THE LIFTING CAPABILITIES?**

4500LBS

### **WHAT HYDRAULIC SYSTEM DO YOU USE?**

POWER UP/ POWER DOWN HYDRAULIC  
SYSTEM

### **CAN I WASH MY CAR ON THE LIFT?**

YES, BUT DO NOT PUT DIRECT WATER  
PRESSURE ON THE CYLINDER SEALS

### **CAN I LEAVE MY CAR ON THE LIFT DURING THE WEEK?**

YES. THERE IS NO LIMIT TO THE DURATION  
OF TIME THE CAR CAN STAY ON THE LIFT

### **HOW MUCH DOES THE LIFT WEIGH?**

67LBS

### **HOW MUCH DOES THE PUMP BOX ASSEMBLY WEIGH?**

65LBS, BUT IT IS ALL HOUSED IN A COMPACT  
ROLL AROUND TOOLBOX

### **WHAT ARE THE SAFETY FEATURES?**

WITH OUR UNIT BEING POWER UP/ POWER  
DOWN WE ARE ABLE TO GO PAST 90  
DEGREES. WHEN THE LIFT IS ALL THE WAY UP  
IT IS LOCKED. ALL LIFTS HAVE A BATTERY  
DISCONNECT FEATURE AS WELL

### **WHAT ARE THE STANDARD DIMENSIONS**

- 41 INCHES OVERALL WIDTH
- 46.75 INCHES LONG
- 3 INCHES TALL WHEN COLLAPSED
- 32 INCHES CENTER TO CENTER



**CONTACT**  
**Info@tricontoolinc.com**

**Cell: 770-787-1002**  
**Office: 770-898-3907**  
**171 Mananatha Road, McDonough, GA. 30252**

## **WHO IS DIRTCARLIFT?**

DirtCarLift.com was established in 2013. The company was built on a need for a better, faster, and safer way to service the racecar at the track or around the shop.

We now have thousands of clients spanning multiple divisions across the U.S, Australia, The Netherlands & Canada.

We pride ourselves in manufacturing a top of line all CNC machined, Power up/Power down, 4500lb lifting capacity hydraulic pit lift that is backed by phenomenal customer service.

DirtCarLift.com is also a proud marketing partner with events and series, which include the Dirt Million, VP Racing Fuels Gateway Dirt Nationals, World of Outlaws, Lucas Oil, Monster Mini Stock Series, Thunder Series, Red Clay 602 Series and many more!



*X Series Assembly*



*Eco Assembly*